

Movelite 35 Motorised Curtain Track

240VAC or 14.8V DC | Battery Operated Motorised Curtain Track System

Product Information

Verosol's **Movelite 35** is available in both battery and mains powered.

Movelite 35 WT RTS is a 240V AC Mains powered curtain motor, whilst the **Movelite 35 WF RTS** is a Wirefree Battery operated 14.8V Motorised Curtain Motor. Both motors utilise the Glydea Curtain Tracking system. Both motor options add a layer of luxury and elegance to your home, with a stunning design that reflects your style.

With our Movelite 35 motorised curtain systems you can control all your curtains easily via your smartphone or a remote control. Using our Movelite 35 WF RTS wirefree battery motor, you can achieve the same result without the need for any electrical hard wiring.

Verosol's Movelite 35 motorised curtain track system provides: Touch Motion to open & close your curtain by simply pulling on the fabric, plus the added security of manual override in case of power failure.

Further Information

For more information visit verosol.com.au or call **1800 721 404**



Technical Information

Product Code	C201.6	C201.5
Product Name	Movelite 35 WT RTS Motorised Curtain Track	Movelite 35 WF RTS Motorised Curtain Track
Motor Type	RTS	RTS
Nominal Torque [nm]	0.6	0.6
Adjustable Linear Speed [cm/s]	15cm/s	15cm/s
Sound Level [dBA]	41	41
Voltage	240V	14.8V
Supply	AC	DC
Maximum Current	0.3A	N/A
Adjustable Limits	Yes	Yes
Curtain Maximum Weight	35kg	35kg
Maximum Track Width [Mtr]	10mtrs	6mtrs
Control Method	RTS RTS remote Connexoon Window RTS	RTS RTS remote Connexoon Window RTS TaHoma
Radio Frequency [MHz]	433.42	433.42
Thermal Time	2.5 minutes	2.5 minutes
Charging Time	N/A	< 6 Hours
Index Protection Rating	IP30	IP30
Electrical Insulation	Class I	Class III
Temperature Working Range	0° C to +60° C	0° C to +60° C
Motor Length L1	283mm	298mm

Turn over for Motor & Track Drawings & Information

Movelite 35 Motorised Curtain Track

1240VAC or 14.8V DC | Battery Operated Motorised Curtain Track System

Movelite 35 WT | RTS Motor
240V AC

Movelite 35 WF RTS Battery Motor [Wirefree]
14.8V DC

Glydea Curtain Track

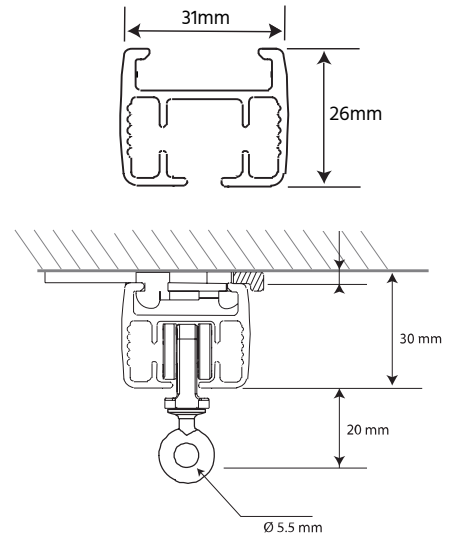
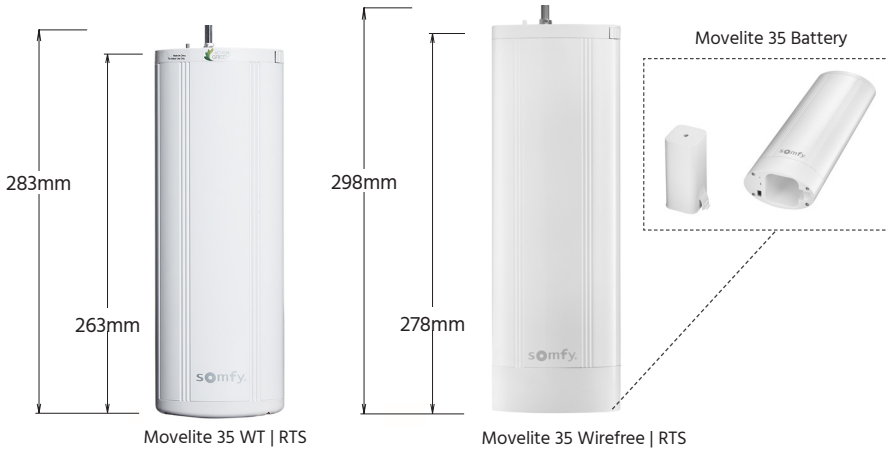

Glydea Track Dimensions - SINGLE Track

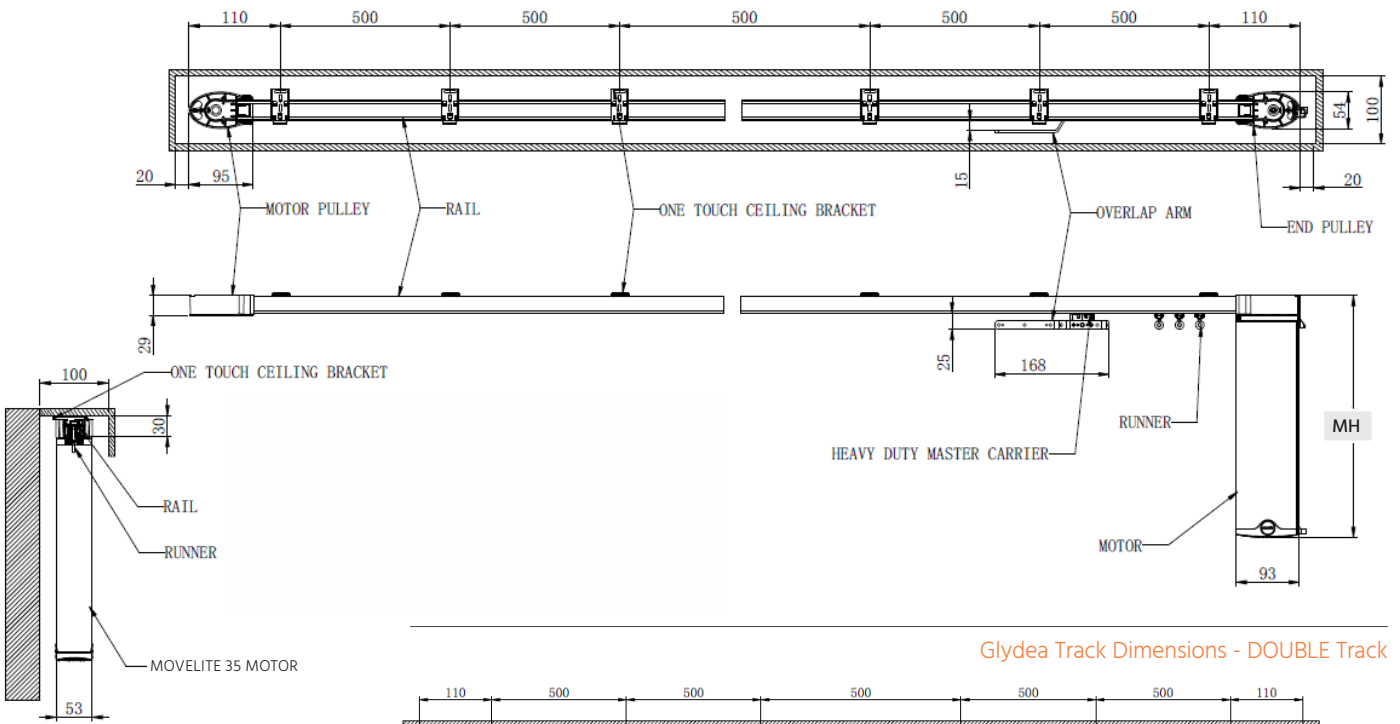

Glydea Track Dimensions - DOUBLE Track

